



Electric Service Standards

DATE
04-12-16

PREPARED BY

SUBJECT

SECTION: PAGE

Delivery Assurance –
Design Support

IV. SERVICE and METER CONNECTIONS

IV: 1 of 24

IV. SERVICE and METER CONNECTIONS

A. Service Equipment

1. General

The Customer should consult FPL at an early stage to verify availability of service ([section II.C](#)) and to determine the FPL designated point of delivery ([section III.B](#)). Contact with FPL should be made before the purchase of equipment and its installation. This FPL approval is not a substitute for inspection and approval by the local electrical inspection authority. FPL assumes no responsibility for the Customer's wiring installation. Upon request, FPL will inform the Customer of available short circuit currents.

The Customer shall provide, install, own, and maintain all service entrance conductors, service equipment, and metering equipment cabinets ([section VI](#)). The service equipment usually consists of a circuit breaker or switch and fuses, and their accessories, located near the point of entrance of the supply conductors to the buildings or otherwise defined area. It is intended to be the main control and means of cutoff of the supply.

FPL will provide, install, own and maintain adequate meters (and other appurtenant equipment as needed) to measure the electrical quantities required to apply its rate schedules and contracts.

The Customer may choose the type of service equipment he prefers, consistent with local building codes and the National Electrical Code (NEC). It shall be able to successfully interrupt the maximum fault current available at its location. Where load growth is possible, FPL recommends that the capacity of service entrance conductors and service equipment be greater than the minimum requirements of the NEC or other local codes. FPL encourages residential Customers to install a service entrance with a capacity of at least 150 amperes for average homes and more in the case of larger homes.

Service entrance equipment shall be in a location which is accessible and not likely to become obstructed.

Meters shall not be located in the median of divided roads or highways.

The customer's service conductors shall be continuous from the point of delivery to the metering equipment. If splice boxes, pull boxes, troughs, or other such items are located in the service run, they shall provide a means of sealing by FPL with standard company meter seals. Conductors installed in raceways shall comply with NEC Article 300.3.

The customer's service conductors shall be marked (tagged) at the source with the location served. See [Fig. IV-14](#) for tagging details.

No fuses should be installed at any point in the grounded neutral conductor of the service entrance.

No resistor or reactor or other similar fault current limiting device shall be installed in the neutral or the phase conductors of the service entrance without the approval of FPL.

Where customer owned stepdown transformers are required they will be installed on the load side of the meters.

Where permitted by applicable codes, the service equipment will be on the load side of the meters except that if the service is fed from the City of Miami Downtown Network Grid, the service equipment will precede the meter.

A main disconnecting switch may be ahead of the meters when more than six meters are grouped ([Fig. IV-12b](#)). This is because the NEC requires a main disconnect switch where it would otherwise be necessary to operate more than six switches to completely disconnect the building service.



Electric Service Standards

DATE
04-12-16

PREPARED BY

SUBJECT

SECTION: PAGE

**Delivery Assurance –
Design Support**

IV. SERVICE and METER CONNECTIONS

IV: 2 of 24

When installed ahead of the meters, the door of the main switch shall be sealable in both the "on" and "off" positions. The handle shall be sealable in the "off" position.

A minimum *horizontal* separation of 3 feet shall be maintained between natural gas service equipment (*vented regulators*) and electric metering or termination equipment. Transformers shall have a minimum separation of 5 feet from natural gas service equipment. A minimum separation of 5' shall be maintained between electric metering or termination equipment and liquid petroleum facilities on site but not filled on site. If the liquid petroleum facilities are filled on site the minimum separation is 10 feet.

All commercial installations and all residential three phase installations must contain lever bypass, jaw tension/release socket blocks with the exception of small (120V or 120/240V, with 100 amp meter enclosure), **non-critical** loads such as:

- Lighted signs and billboards
- Temporary construction poles and service to construction trailers
- Irrigation pumps
- Residential detached garages
- Gate openers
- Barns
- Apartment / Condo house meters
- Bus stops
- Street lighting

The use of a Metallic fishtape to pull service conductors into FPL owned equipment is not allowed.

2. Ampere Rating

a. Residential

The rating of the service entrance equipment shall satisfy the general requirements stated above, the NEC and local building codes. Article 230 of the NEC states that the minimum rating for a one family dwelling with six or more two-wire branch circuits, or an initial computed load of 10 kVA or more is 100 ampere, three-wire. For dwelling units with less load, as computed in accordance with NEC guidelines, the minimum may be 60 ampere, three wire if approved by the inspecting authority. In very special cases where the load is only one or two two-wire branch circuits, the service disconnecting means may have a rating of no less than 15 amperes or 30 amperes, respectively, if approved by the inspecting authority.

As stated previously, FPL recommends that the service entrance have more capacity than the minimum required by the NEC. Local inspecting authorities shall be consulted, since some locations may have requirements that exceed the minimums.

b. Commercial

The rating of the service equipment for commercial or industrial occupancies will depend on the connected load, and in most cases, will be specified by the Customer's engineer.



Electric Service Standards

DATE
04-12-16

PREPARED BY

SUBJECT

SECTION: PAGE

**Delivery Assurance –
Design Support**

IV. SERVICE and METER CONNECTIONS

IV: 3 of 24

It is important that the requirements be reviewed with FPL at an early date so that a satisfactory solution as to service voltage and service entrance location can be determined. At this time, details as to the nature and size load to be served may be given to FPL, if this has not already been done.

The service equipment should be chosen to satisfy all the requirements of the Customer for the control of his load and should be consistent with the NEC, local building codes and the rules of the inspecting authority.

One requirement is that the service equipment shall be able to safely interrupt the maximum fault current available at its location. Upon request, FPL will supply information which will permit the maximum available fault current to be determined.

FPL emphasizes that changes in the Customer's load and other loads in the area may require changes in FPL's system. These changes may increase the available fault current. Allowance should be made for this possible increase.

c. Service Equipment Rated Below 600 Volts

In those cases where the Customer's ampere demand at these voltages exceeds 600 amperes, or the Customer's service entrance wire size exceeds 1-800 KCMIL or 2-500 KCMIL conductors, per phase, FPL will normally require the Customer to furnish a current transformer cabinet and an instrument transformer rated meter socket, installed ahead of his service equipment. The Customer will also furnish and install a 1-1/2 inch conduit from the cabinet to the meter socket (refer to the specifications found in [section VI](#)). FPL will provide and perform the current transformer installation, install the secondary wiring from the current transformer to the meter socket, and install the meter.

On all self-contained metered installations (320 amperes or less) where the service voltage is 480V to ground (2 wire), a non-automatic disconnect device shall be provided and installed by the Customer on the line side of each individual meter. The disconnect device shall be lockable or sealable by FPL and adjacent to each meter. The Customer-owned non-automatic (no over current protection) disconnect device ampacity must meet all NEC Guidelines. A lever bypass equipped meter enclosure is required and shall be selected from the Approved Meter Equipment Enclosure List.

For service disconnecting means rated 1,000 amperes or more used on a solidly grounded 277/480 volt wye service, ground-fault protection shall be provided. This may be omitted, if approved by the inspecting authority or if the service equipment controls a continuous industrial process where a non-orderly shutdown would otherwise introduce additional or increased hazards.

Where for any reason, a main disconnecting switch is required in multi-metered service installations; it will be on the line side of the meters. The door of this switch box shall be sealable. No socket or current transformer cabinet will be required ahead of this switch.

d. Service Equipment Rated Over 600 Volts

When the Customer takes service at primary voltage, he shall provide service equipment rated for the voltage supplied. The service equipment will normally be on the load side of FPL's instrument transformer metering installation.



Electric Service Standards

DATE
04-12-16

PREPARED BY

SUBJECT

SECTION: PAGE

**Delivery Assurance –
Design Support**

IV. SERVICE and METER CONNECTIONS

IV: 4 of 24

The service equipment shall satisfy all the requirements of the NEC, the building code, and the inspecting authority.

FPL shall be consulted so that the Customer's primary service equipment may be coordinated with FPL's feeder protection circuit breakers and fuses.

For padmounted primary metering, the customer will either provide a metering cabinet listed on FPL's approved enclosure list, or FPL will provide the metering cabinet and bill the customer the cost. For primary metering in vaults, FPL will provide, own, and maintain the metering cabinet located inside the vault.

B. Overhead Service

For residential overhead service, the attachment will normally be within ten feet of the corner, on the side of the building nearest FPL's secondary facilities (**Fig. IV-4**). The Customer's service entrance should be installed in such fashion that service drop wires will not cross over buildings, swimming pools, or adjacent property not owned by the Customer. FPL may provide the Customer with two copies of an "Electric Service and Meter Location" sketch (FPL form 1453) confirming the service location (**Fig. IV-3**).

1. Vertical Clearance to Ground

The point of attachment for service drops not exceeding 150 volts from any conductor to ground shall allow ten feet of ground clearance to lowest point of sag in the service drop.

Service drops exceeding 150 volts but less than 300 volts from any conductor to ground shall allow ten & one-half feet of ground clearance to lowest point of sag.

Where the service drop must pass over immediately adjacent driveways or parking areas subject to truck traffic or if it is within 25 feet of a swimming pool or if the voltage to ground is over 300 volts, additional clearance shall be provided. In these cases a greater attachment height shall be provided.

The required attachment height will be shown on the "Electric Service & Meter Location" sketch. It is important the Customer furnish this information to the building contractor and electrician.

2. Clearance from Building Openings

Service conductors shall have a clearance of not less than three feet from windows, doors, porches, fire escapes or similar openings.

3. Clearance from Swimming Pools

FPL prefers a minimum horizontal clearance of 10 feet from its facilities to swimming pool edges or pool enclosures. However if certain conditions are met, including minimum vertical clearances, the National Electrical Safety Code (NESC) provides for less than 10 feet of horizontal separation. Costly relocations of existing services may become necessary if the Customer builds a pool too near FPL's electric facilities. Should there be any question of conflict between the location of a new swimming pool or pool enclosure and FPL's facilities; the Customer is to contact FPL before construction of the pool facilities to ensure required NESC clearances are met.



Electric Service Standards

DATE
04-12-16

PREPARED BY

SUBJECT

SECTION: PAGE

**Delivery Assurance –
Design Support**

IV. SERVICE and METER CONNECTIONS

IV: 5 of 24

4. Anchorage for Overhead Service Drop Cable or Wires

The Customer shall provide a safe and adequate anchorage for FPL's overhead service drop conductors at the agreed upon location and height.

FPL will furnish, and the Customer will install, a suitable attachment for the service drop. The attachment device furnished will vary, to be compatible with the type of building construction (**Fig. IV-6a thru 6c**).

FPL WILL NOT BE RESPONSIBLE FOR DAMAGE TO THE CUSTOMER'S BUILDING OR WIRING RESULTING FROM FAILURE OF THIS ANCHORAGE.

The point of service drop attachment and its height will be shown on the "Electric Service and Meter Location" sketch. It should be sufficient to provide all the required clearances as shown in **Fig. IV-5**. The location should be accessible from the ground by a ladder.

Where the height of the building would not allow adequate clearance from service drop to ground, the Customer shall furnish and install a service mast or other approved extension (**Fig. IV-6a**). FPL will provide and install the bracket for attaching the service drop to the service mast.

5. Installation of Service Entrance

The service entrance conductors shall be provided and installed by the customer in accordance with local building codes and the latest NEC. The conductors will extend a minimum of 36 inches beyond the service weatherhead to permit connection to FPL's service drop wires. FPL limits the number of customer conductors per service to three per phase (i.e. - 3 weatherheads with one conductor per phase; or 2 weatherheads - one with parallel conductors and one with single conductors; or 1 weatherhead with three conductors per phase where allowed by code). Call your local new construction office in situations where the load exceeds the capacity of three 750 KCMIL AL or CU conductors per phase.

The service entrance weatherhead shall be above the service drop attachment. If this is impractical, the weatherhead shall not be farther than 24" from the point of attachment.

Service drop conductors and service entrance conductors will be arranged in a manner that will prevent water from getting into the service entrance raceway or cable sheath (**Fig. IV-6a**).

The neutral conductor of the service entrance shall be identified by the Customer.

Wiring of the meter socket shall be as shown in the appropriate sketch of **Fig. IV-8**.

The service entrance conduit is installed by the Customer from the service weatherhead to the meter socket or the service entrance equipment, when this precedes the meter. It may be either exposed on the exterior building wall, or concealed within the structure itself in a permanently inaccessible location. Condulets (such as LB, LL, LR) shall not be used. Where exposed to the weather, conduit shall have threaded joints and shall be arranged to drain.

In the case of the service entrance conductors for a three phase, four wire delta service, one of the ungrounded conductors will have a higher voltage to ground than the other two conductors (**Fig. IV-8**, Meter Symbol J). This conductor shall be durably and permanently marked by an outer finish that is orange in color or by other durable effective means, and landed on the right side of the meter can. This marking will ensure connection to the proper FPL conductor when the service is connected.

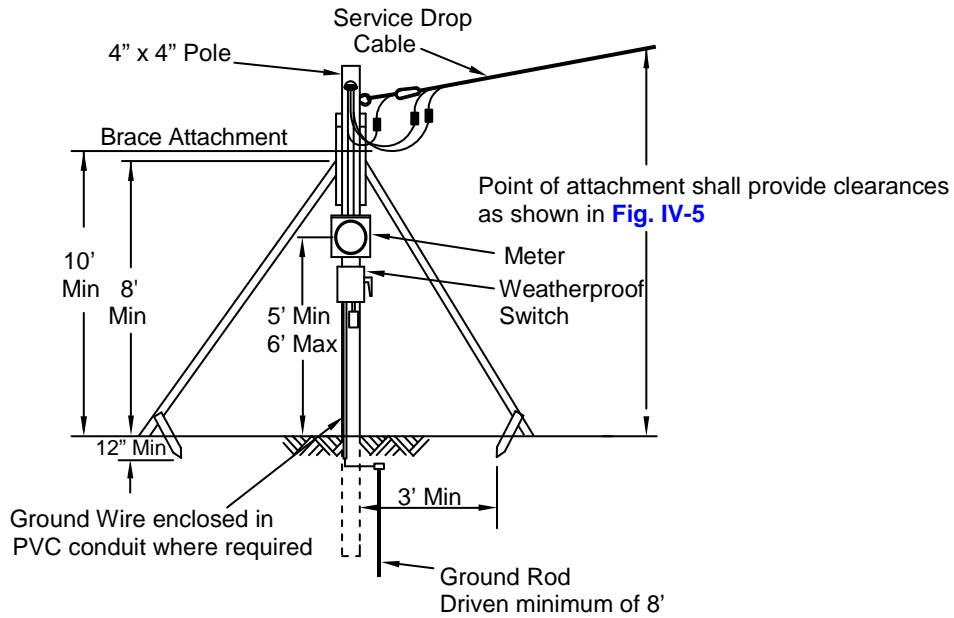
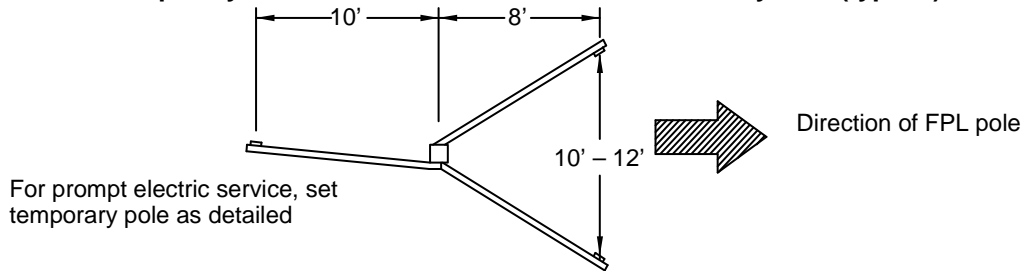
C. Illustrations

The following illustrations contain pertinent information regarding the installation and connection of overhead and underground services.



FIGURE IV-1

Temporary/Construction Service - from Overhead System (typical)

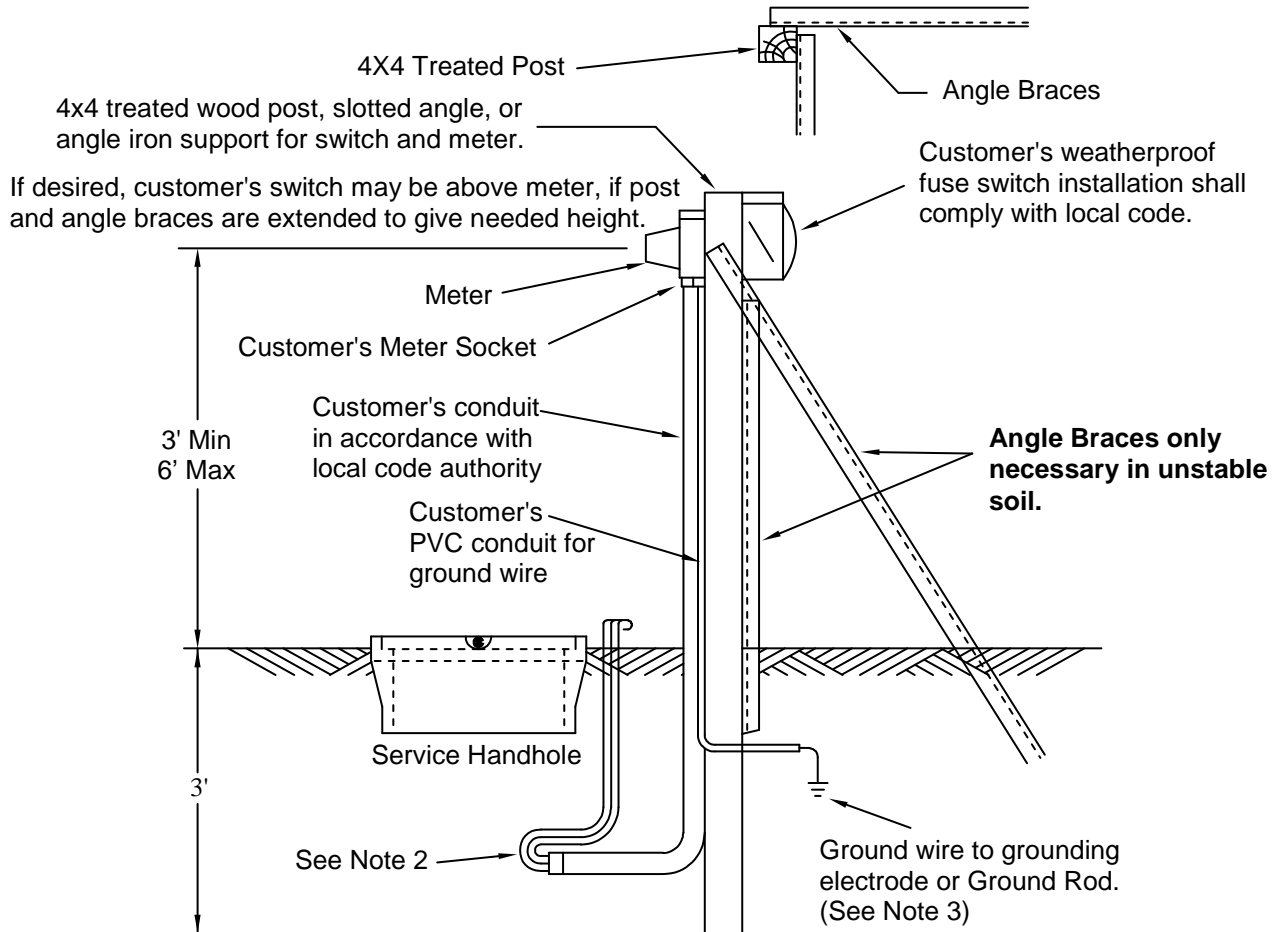


Notes:

1. Before service can be run, Company must have an electrical inspection; necessary tree trimming shall be done by the customer; and the deposit and non-refundable temporary service charge shall be paid.
2. Service pole shall not be within 25 ft. of swimming pool and must provide clearances shown in [Fig. IV-5](#).
3. Unspliced timbers are required (minimum length of 12 ft. for 2x4 braces and 16 ft. for 4x4 posts. Use ten penny (10d) nails (3" long).
4. Special arrangements shall be made with FPL if service drop exceeds 80 ft. or is larger than 200 amp capacity.
5. Minimum typical requirements are shown. If local code requirements are more stringent, they shall be adhered to.
6. The surface the meter socket is mounted on shall be plumb so the meter socket jaws are truly vertical. The meter enclosure must be on FPL's approved list.
7. Where acceptable to the inspecting authority, an 18 ft. treated pole (5" min. diameter at the top) may be substituted for the 4x4 timber and braces, provided the pole is set 5 ft. deep and well tamped. All other requirements remain the same.



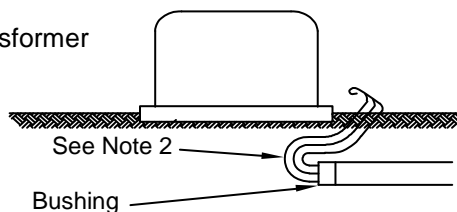
FIGURE IV-2
Temporary/Construction Service - from Underground System (typical)



Notes:

1. Before service can be connected, the company must have the electrical inspection; necessary grading shall be done by the customer; and the deposit and non-refundable temporary service charge shall be paid. Contact the FPL representative for availability and location.
2. The customer shall leave a five foot length of service conductor above ground, outside of source, for connection to FPL secondary by FPL.
3. Temporary service should be located outside the utility easement to avoid driving the ground rod into any existing underground cables.
4. Service Conductors shall be near secondary side of the transformer.
5. The meter enclosure must be on FPL's approved list.

Padmounted Transformer





Electric Service Standards

DATE 04-12-16

PREPARED BY

SUBJECT

SECTION: PAGE

Delivery Assurance – Design Support

IV. SERVICE and METER CONNECTIONS

IV: 8 of 24

FIGURE IV-3

FPL Electric Service and Meter Socket Requirements Form

APPLICANT _____ Current FPL Account No. _____
MAILING ADDRESS _____ CITY, ZIP CODE _____
SERVICE ADDRESS/LEGAL DESCRIPTION _____
PHONE (WEEKDAYS) _____ DATE _____

FPL is pleased to advise that electric service for your proposed _____ will be available from our Distribution facilities as shown on the sketch below. We understand you are requesting ___Overhead ___Underground, ___ volts, ___ phase service. The items checked below and receipt by our representative of the white copy of this form with your signature acknowledging your receipt, are required before FPL provides electric service:

Payment:
___ Construction/Temporary Service Charge: \$ _____
(Check or ___ Security Deposit for Construction/Temporary Service: \$ _____
Money Order) ___ Underground/Overhead Differential Charge for Permanent Service: \$ _____
___ Line Extension Contribution In Aid of Construction (CIAC): \$ _____
Total: \$ _____

___ Tree Trimming & Clearing: _____ Feet
___ Each Side of Proposed Line
___ Installation of Meter Socket & Downpipe/
___ Weatherhead according to FPL Specifications
___ (see checklist on reverse side of this sheet)
___ Install eyebolt (for FPL to attach wires to)
___ Configuration _ Meter Socket*
___ Site Plan ___ Electrical Load Information/Plans
___ Easement for FPL Facilities/Legal Description of Property
___ Contact FPL ___ days before Certificate of Occupancy
___ concerning Application/Security Deposit for permanent
___ service.
___ Final City/County Electrical Inspection
___ \$ _____ Security Deposit _____ is required before _____ will be billed after
___ permanent service provided. ___Other:

*Meter socket must be approved for use in FPL service area. Current list of approved sockets available upon request. Socket configurations are shown on reverse side of this form.

For overhead service, minimum attachment height is to be 12 feet above grade. For underground service, minimum cover is to be 24 inches (maximum 36 inches). FPL specifications and requirements must be adhered to and are available upon request. Upon timely completion of the above required items and agreement between you and our Representative, service may be provided approximately the week of _____ or as mutually agreed upon. Changes to type service requested, failure to comply with above requirements, or delays to FPL's construction schedule may affect proposed date of service.

"SERVICE LOCATION SKETCH"

INDICATE NORTH

PLEASE SIGN ON THE LINE PROVIDED BELOW, RETAIN A COPY AND RETURN A COPY TO FPL.

RECEIPT IS HEREBY ACKNOWLEDGED:

MAKE INQUIRIES TO:

APPLICANT _____ DATE _____

TITLE (IF CORPORATION) _____

BY (OTHER THAN APPLICANT) _____



FIGURE IV-4
Guide for Locating Point of Delivery on Outside of Building

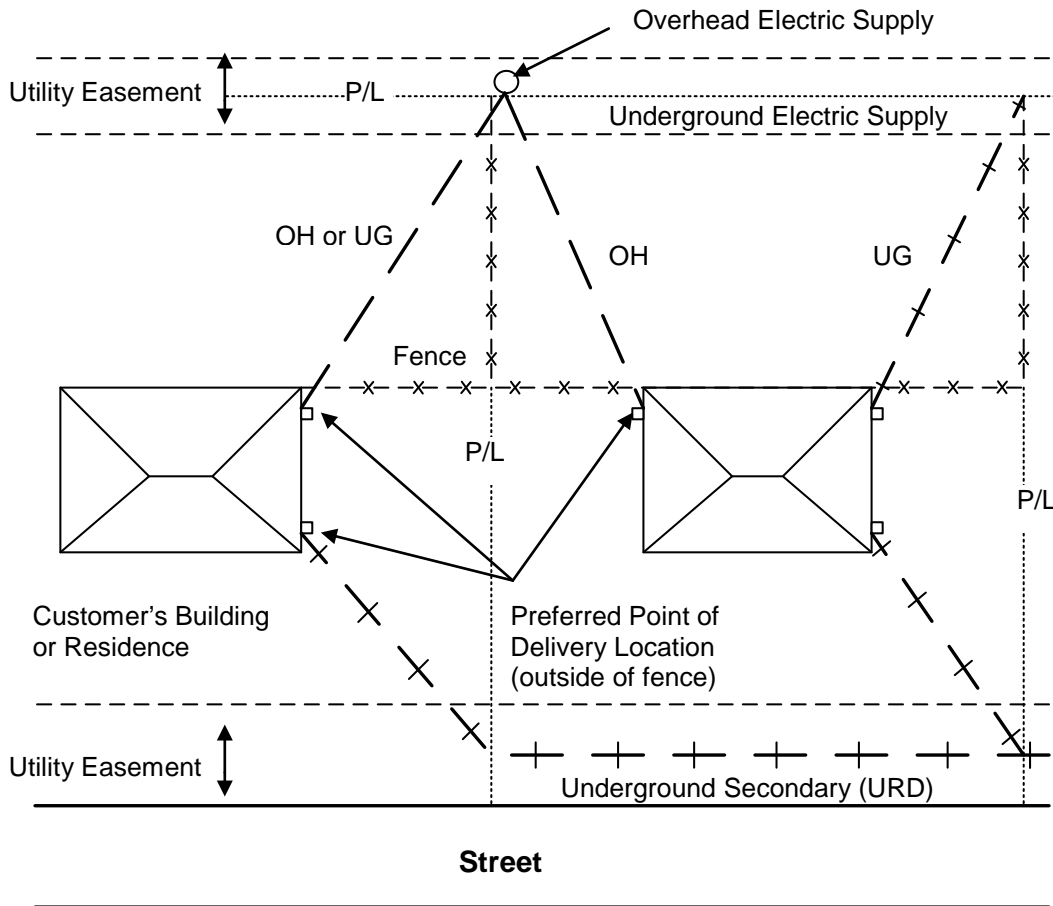
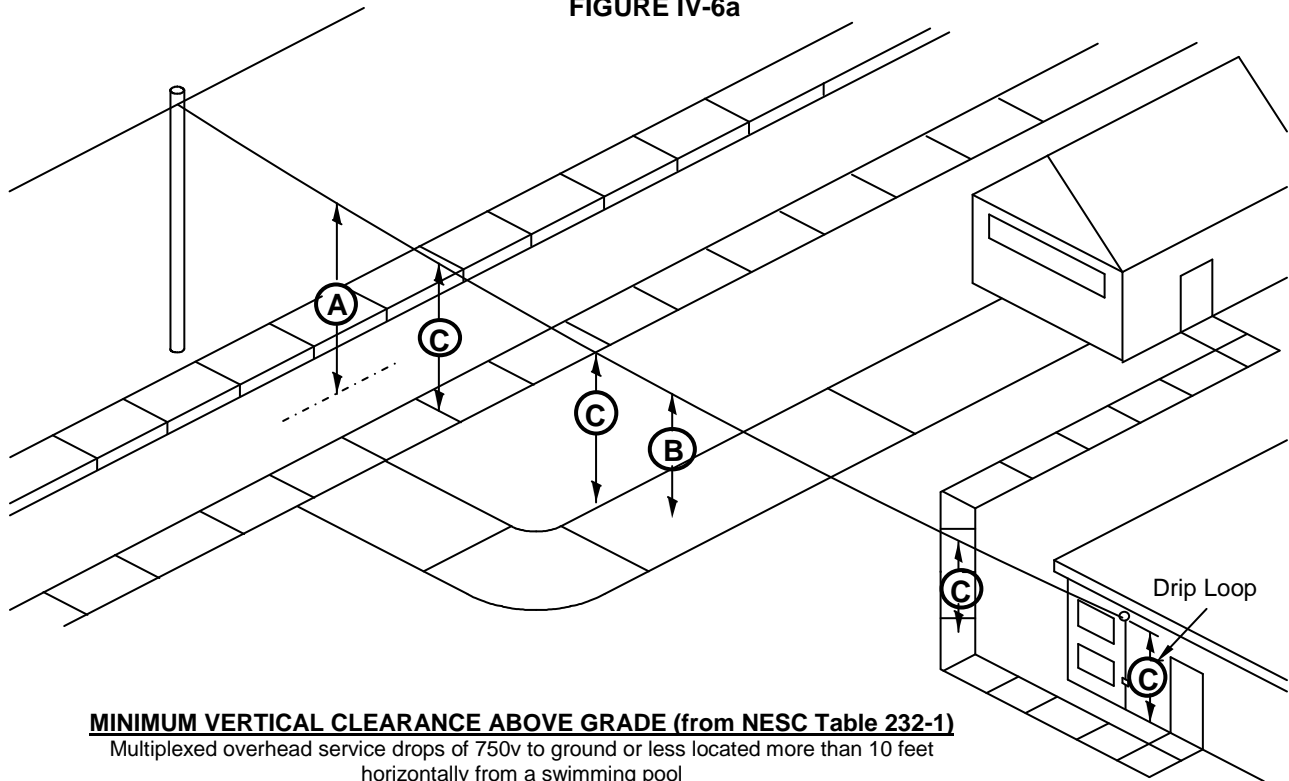




FIGURE IV-5
Overhead Service - Minimum Vertical Clearances
FIGURE IV-6a



MINIMUM VERTICAL CLEARANCE ABOVE GRADE (from NESC Table 232-1)

Multiplexed overhead service drops of 750v to ground or less located more than 10 feet horizontally from a swimming pool

A. Roads, streets and other areas subject to truck traffic 16 feet (NEC = 18')

B. Driveways, parking lots and alleys 15 feet (NEC = 18')

Exception - Residential driveways only where attachment height at building does not permit 15 feet of clearance:

Voltage limited to 300v to ground:

Service Drops 12.5 feet (NEC = 12')

Drip Loops 10.5 feet (NEC = 12')

Voltage limited to 150v to ground:

Service Drops 12 feet (NEC = 12')

Drip Loops 10 feet (NEC = 12')

C. Spaces and ways subject to pedestrian or restricted traffic only..... 12 feet (NEC = 12')

Exception - Where attachment height at building does not permit 12 feet of clearance:

Voltage limited to 300v to ground:

Service drops and drip loops 10.5 feet (NEC = 12')

Voltage limited to 150v to ground:

Service drops and drip loops 10 feet (NEC = 10')

D. Other land (such as cultivated, grazing, forest, orchard, etc.) traversed by vehicles 16 feet (NEC = 18')

NOTES:

-120v single phase, 120/240v single phase, and 120/208v wye 3 phase services meet the 150v to ground criteria.

-120/240v open or closed delta 3 phase and 277/480v wye 3 phase services meet the 300v to ground criteria.

-240/480v delta services do not meet either the 150v or 300v to ground criteria and do not qualify for the exception to the basic clearance.

The clearances above are NESC minimum values for worst-case sag conditions. The attachment height at the building or customer's service pole must be sufficient to provide these clearances for all situations involved. Good judgment dictates that initial installation be made at higher values to ensure code compliance under worst-case sag conditions. For additional details and clarification regarding these and all clearances, refer to Article 23 of the NESC.



Electric Service Standards

DATE
04-12-16

PREPARED BY

SUBJECT

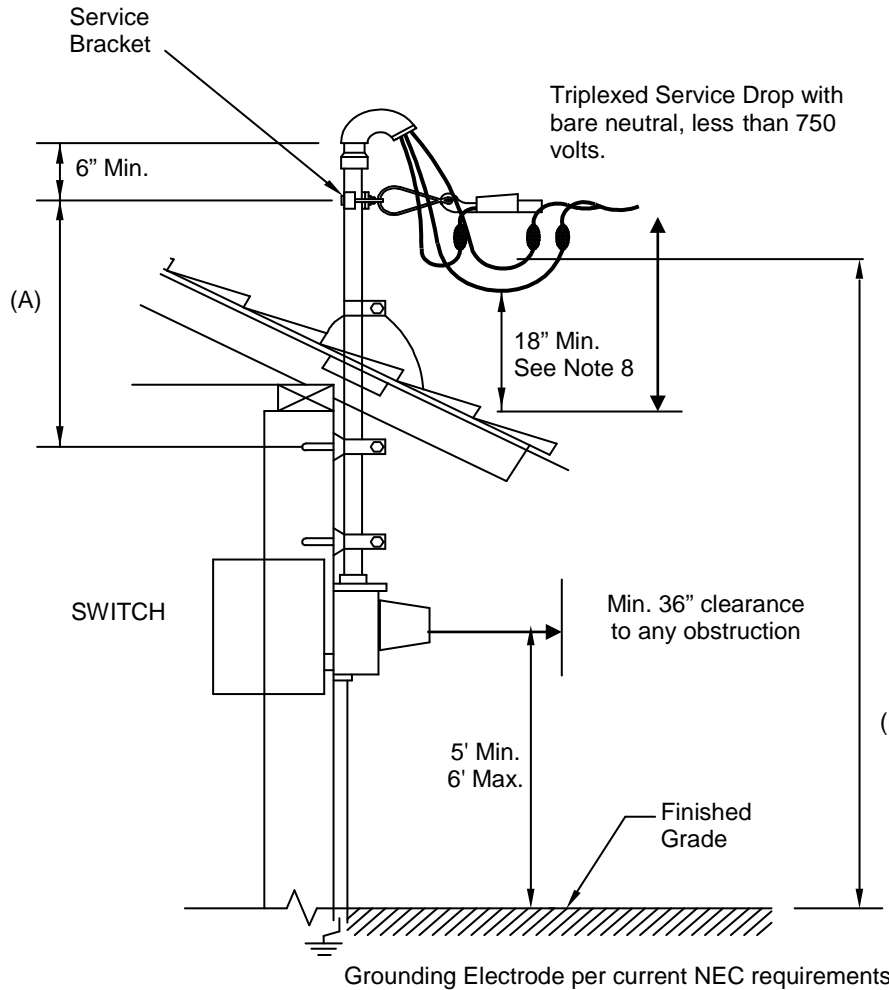
SECTION: PAGE

Delivery Assurance –
Design Support

IV. SERVICE and METER CONNECTIONS

IV: 11 of 24

Attachment of Service Drop at Buildings - to the Pipe Mast



Maximum Service Bracket attachment height above last firm support (A)	
Diameter (Inches)	Rigid Metallic* or IMC (feet)
2	2.5
2-1/2	4.75
3	7.66
3-1/2	10.66

*Rigid Metallic shall be per ANSI C-80.1 and shall be hot dipped galvanized inside and out.

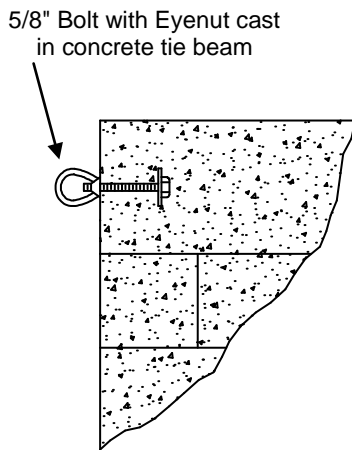
10 ft. Min.
150v to Ground
(refer to [Fig. IV-5](#))

Notes:

1. A service Mast may be used to get proper clearance if permitted by local code.
2. The Service Drop and Service Bracket are provided and installed by FPL.
3. Service Mast or other approved attachment post or bracket must be sufficient strength to support the Service Drop. 2" or larger rigid galvanized conduit is preferred. The point of attachment must be sufficient height to provide minimum clearances. FPL will not attach Service Drop to an aluminum, EMT, or PVC mast.
4. Customer provides and installs Service Mast in accordance with National Electrical Code and/or local codes.
5. Minimum clearance to Drip Loops is 10 feet from ground. Minimum Drip Loop to Roof clearance is 18 inches.
6. Service Drop, Service Bracket and Meter are owned and installed by FPL. Meter Socket is owned, installed and maintained by customer.
7. Service Drop clearance required at locations other than a house are shown in [Fig. IV-5](#).
8. For triplexed or quadraplexed cable services, less than 750 volts, with bare neutral, the 18" minimum clearance is allowed only where no more than 6 feet, measured horizontally, of the service drop passes over a roof to terminate at a through-the-roof mast located not more than 4 feet, measured horizontally, from the nearest edge of the roof. Otherwise, the minimum clearance above the roof (not readily accessible) of the building to which the service is attached is 3 feet. Refer to NESC 234C3d.

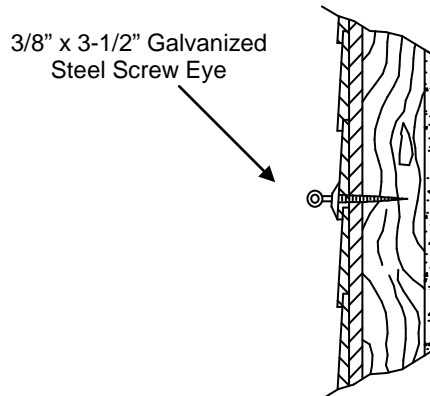


FIGURE IV-6b
Attachment of Service Drop at Buildings - to the Structure



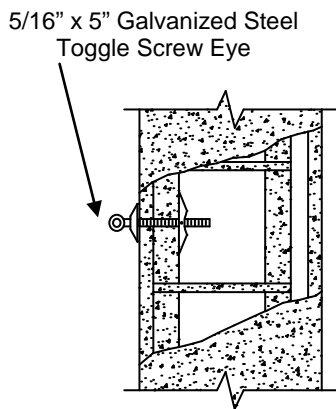
If point of service attachment can be determined before construction, an effort should be made to have eyebolt installed during construction

ALTERNATIVE #1



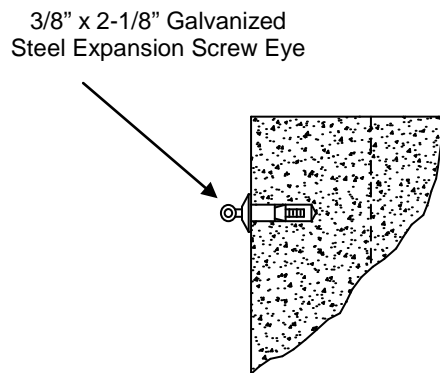
When attachment must be made to building frame use 3/8" x 3-1/2" screw eye. Drill thru siding with 3/8" bit. Use 1/4" bit to precede screw into stud.

ALTERNATIVE #2



Use toggle screw eye on hollow tile or concrete block walls

ALTERNATIVE #3



Use expansion screw eye in poured concrete walls or beam

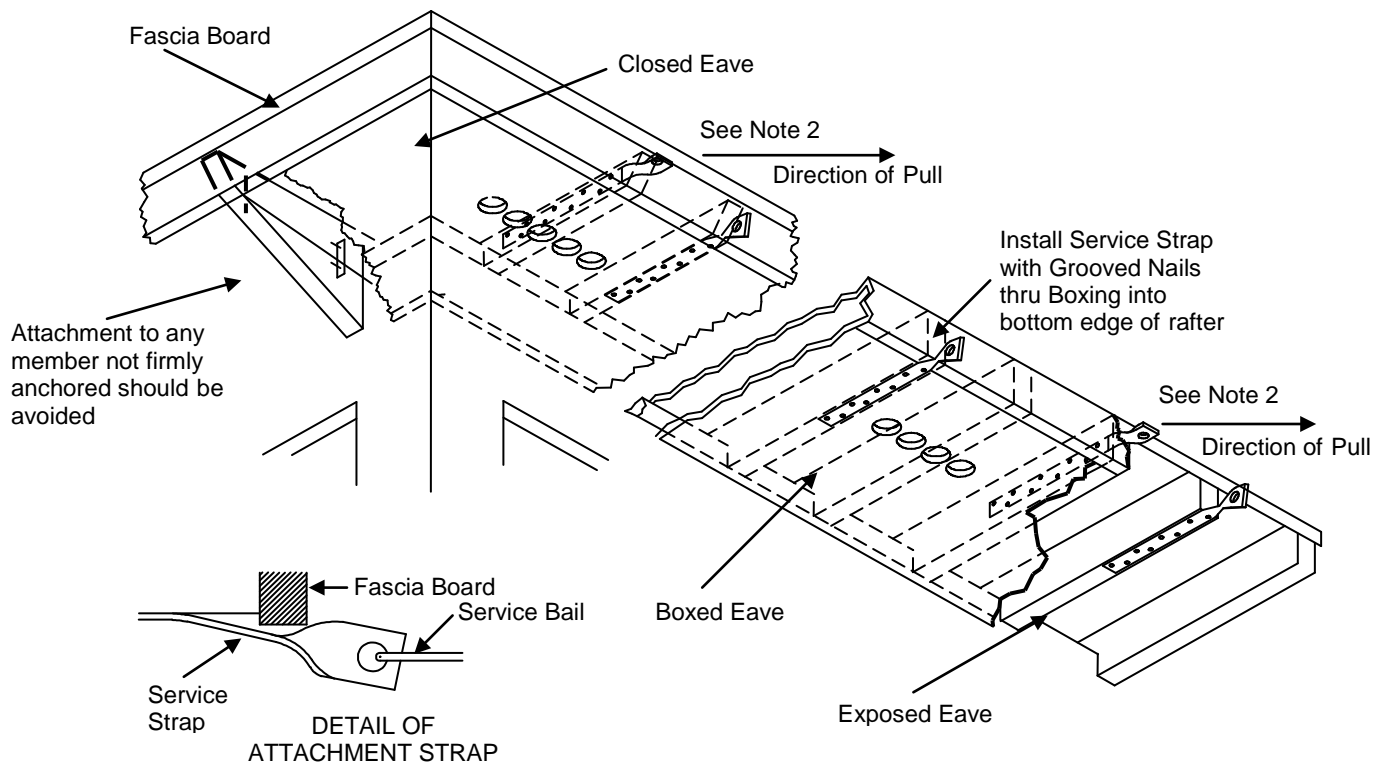
ALTERNATIVE #4

NOTE: Where local building codes are more conservative, they take precedence.



FIGURE IV-6c
Attachment of Service Drop at Buildings - to the Wood Eave
TYPICAL METHODS

To be used only when anchorage into wall will not provide proper ground clearance



Notes:

1. Attach Service Strap with 2-1/2", No. 8 gauge "Anchor Fast" grooved nails.
2. If angle between Service Strap and Service Cable is greater than 45 degrees, the strap should be attached on side of rafter opposite direction of Service Pull.



Electric Service Standards

DATE
04-12-16

PREPARED BY

SUBJECT

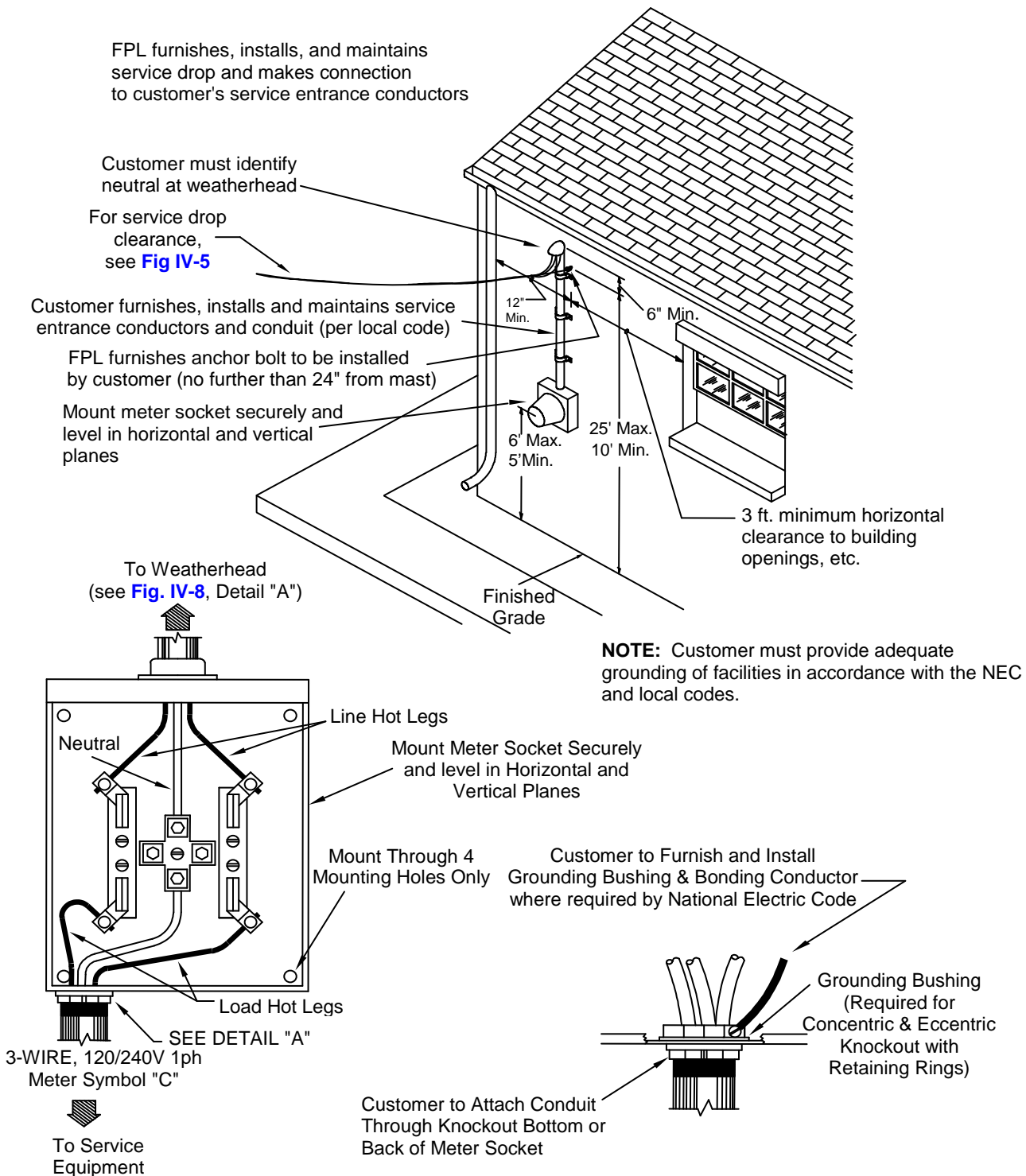
SECTION: PAGE

Delivery Assurance –
Design Support

IV. SERVICE and METER CONNECTIONS

IV: 14 of 24

FIGURE IV-7 Outdoor Meter Installation - 1ph 120/240v 3 wire Overhead Service



DETAIL "A" BONDING AROUND CONCENTRIC & ECCENTRIC KNOCKOUTS



FPL

Electric Service Standards

DATE

04-12-16

PREPARED BY

SUBJECT

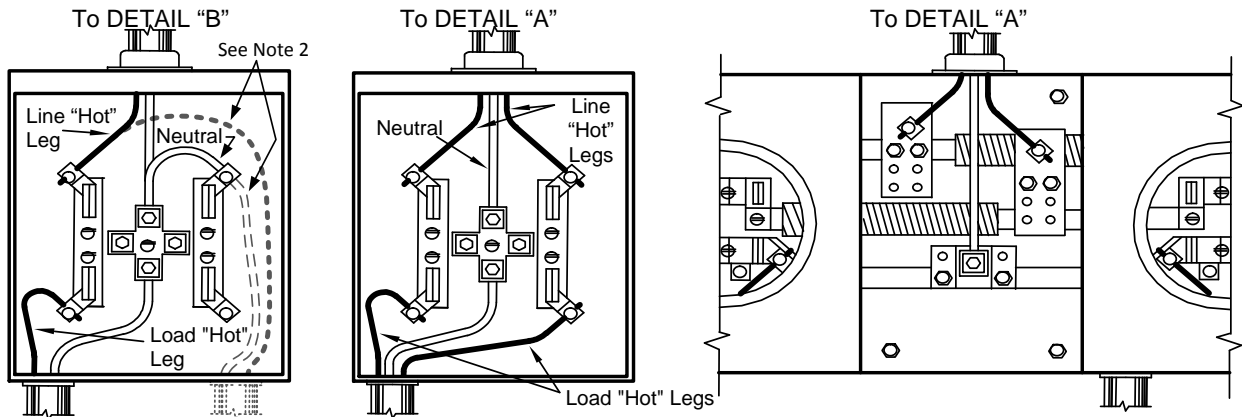
SECTION: PAGE

Delivery Assurance – Design Support

IV. SERVICE and METER CONNECTIONS

IV: 15 of 24

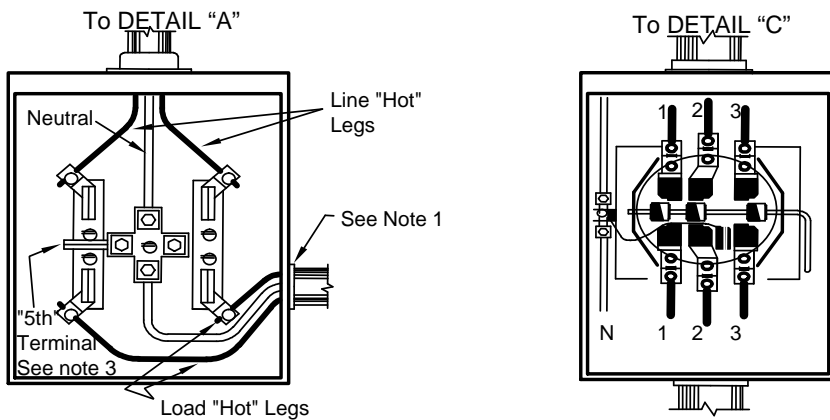
FIGURE IV-8 Self Contained Meter Installation - Overhead Service



2-Wire, 120V 1ph Meter Symbol "A"
 2-Wire, 240V 1ph Meter Symbol "B"
 2-Wire, 480V 1ph Meter Symbol "I"

3-Wire, 120/240V 1ph
 Meter Symbol "C"

Multiple Meter Socket Enclosure
 (3-Wire, 120/240V 1ph shown as typical)



3-Wire, 120/208V Y 1ph (2 Stator network)
 Meter Symbol "E"
 3-Wire, 240/480V 1ph Meter Symbol "G"

4-Wire, 3ph
 Delta: Meter Symbol "J"
 Wye: Meter Symbol "L" & "N"

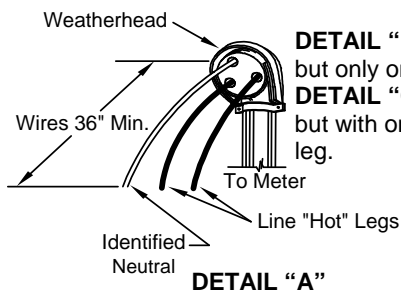
Meter Cans with Bypass Handles

Commercial Applications:

Wiring similar for wye and delta, but on delta, Hot Wire #3 (hi-leg) must be 208V to ground and must be connected to right terminal as shown (other two hot wires, lighting legs, are 120V to ground).

Underground Residential Applications:

Risers for FPL underground services must be installed on the opposite side of the meter can from the customer's service entrance conductors. Customer's conductors **MUST** be kept entirely to one side of the meter can, leaving the opposite side of the meter can unobstructed for FPL's conductor.



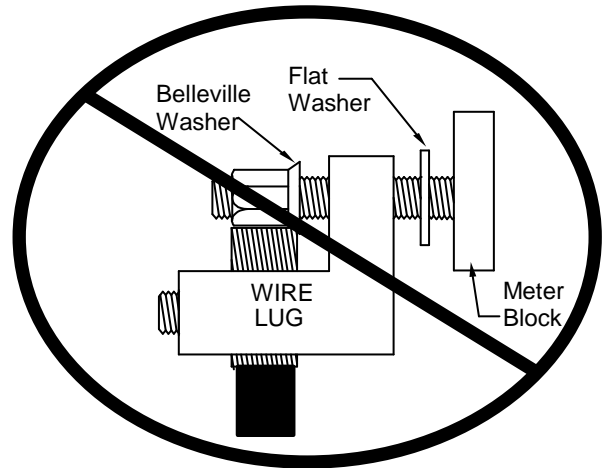
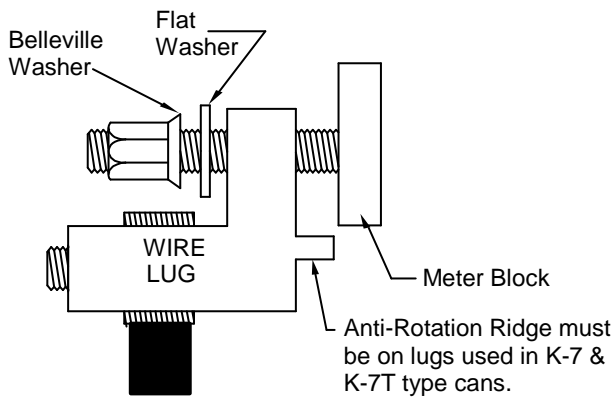
DETAIL "B": same as DETAIL "A", but only one line "Hot" leg.
DETAIL "C": same as DETAIL "A", but with one additional line "Hot" leg.

Note:

1. Customer to bond around concentric knockouts. See Fig. IV-7, Detail "A".
2. For 2-wire installations served from an underground riser, the line neutral conductor may be passed continuously through the upper right lug (shown dashed in figure).
3. 5th Terminal must be connected to the neutral bus either by directly mounting to the neutral bus or by a white 18 ga. wire connecting the terminal to the neutral bus.



FIGURE IV-9
Lug-Type Meter Socket Installations



ACCEPTABLE

NOT ACCEPTABLE

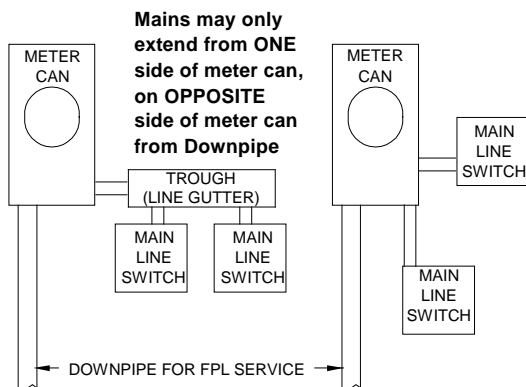
PROPER INSTALLATION OF WASHERS & LUGS ON LUG-TYPE METER CANS

Be sure the flat washer is placed between the Belleville Washer and the wire lug. This installation will ensure the maximum surface contact area of the lug and the meter block.

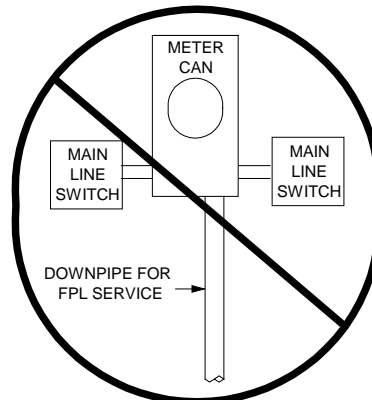
Be sure the wire is placed properly in the lug so it will not interfere with the tightening of the Belleville Washer.

The lug used in the 400 amp (K-7, no new installations – maintenance only) and 600 amp (K-7T) cans must have an anti-rotation ridge as shown. This ridge is not required in smaller cans.

*****ACCEPTABLE CONFIGURATIONS*****



*****NOT ACCEPTABLE*****



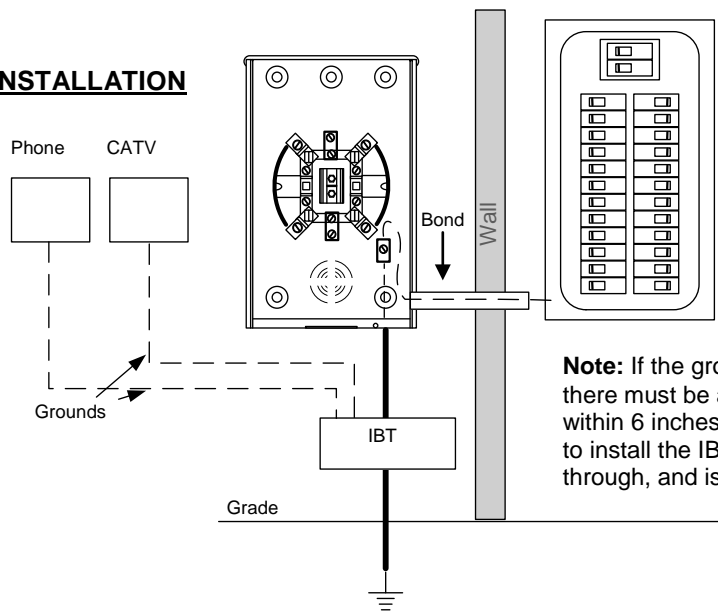
In underground installations, when customer's conductors are parallel, customers conductors **MUST** be kept entirely to one side of the meter can, leaving the opposite side of the meter can unobstructed for FPL's conductor. When load conductors enter through the bottom rear of the meter can they must be kept entirely to one side so not to interfere with the FPL conductor.



FIGURE IV-10
Intersystem Bonding Termination

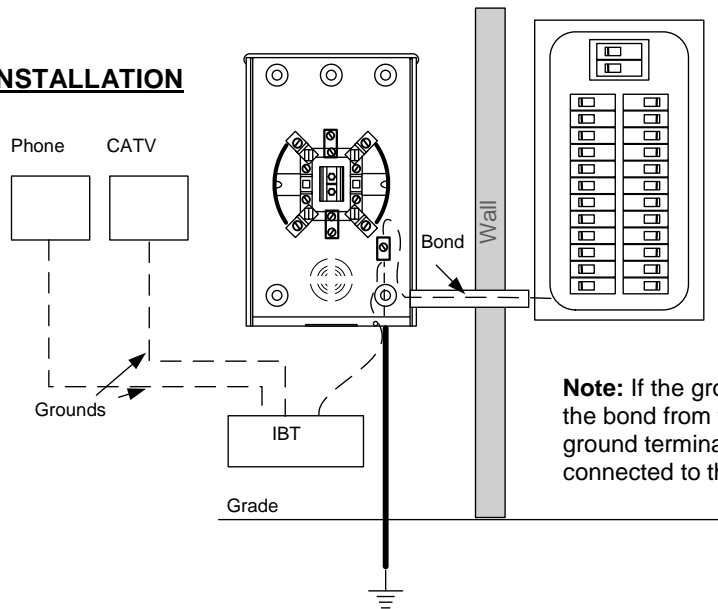
NEC Article 250.94 has been revised in the 2008 Code, thereby affecting all new installations and existing installations where alterations are made. The Code has identified a new device called the **Intersystem Bonding Termination** or IBT. The IBT is defined as "a device that provides a means for connecting communications system(s), grounding conductor(s) and bonding conductor(s) at the service equipment or *metering equipment enclosure** or at the disconnecting means for buildings or structures supplied by a feeder or branch circuit."

PREFERRED INSTALLATION



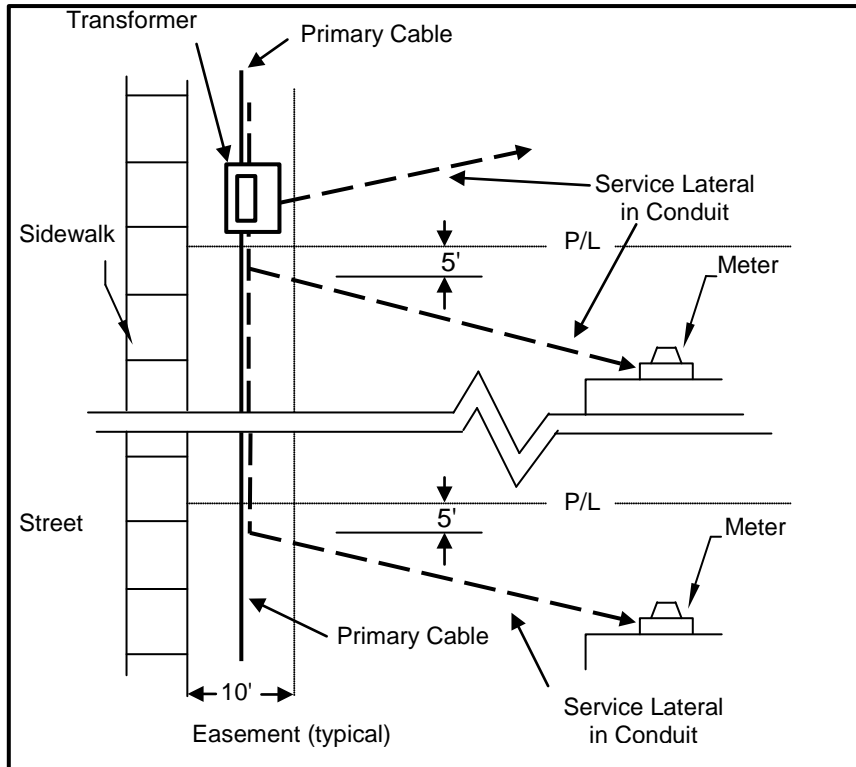
Note: If the ground wire is enclosed in conduit, there must be an exposed section of ground wire within 6 inches of the bottom of the meter enclosure to install the IBT. The ground wire runs unbroken through, and is attached to, the IBT.

ALTERNATE INSTALLATION



Note: If the ground wire is enclosed in conduit, the bond from the panel is looped through the ground terminal in the meter enclosure and connected to the IBT.

**FIGURE IV-11a
URD System Layout - Typical**

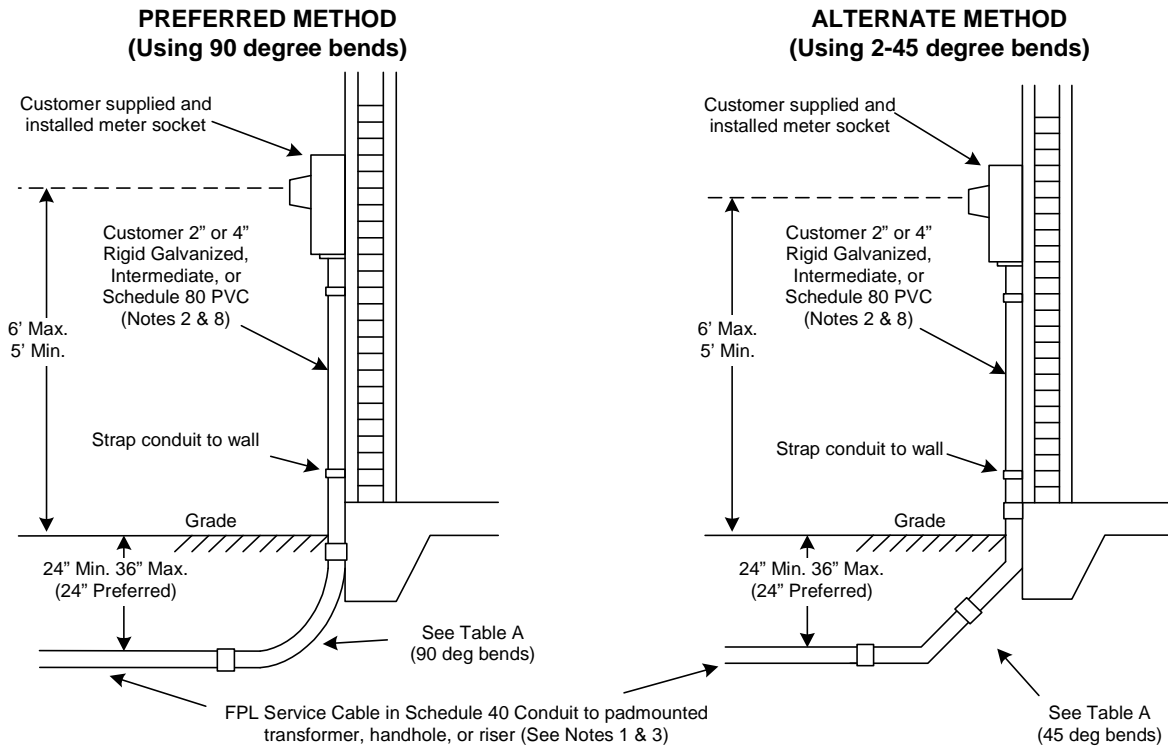


NOTES: (APPLICABLE TO FIGURES 11a and 11b)

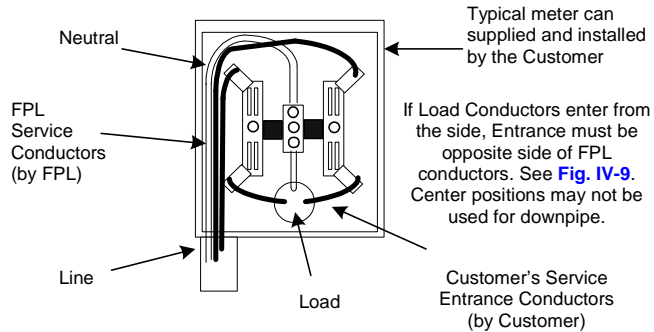
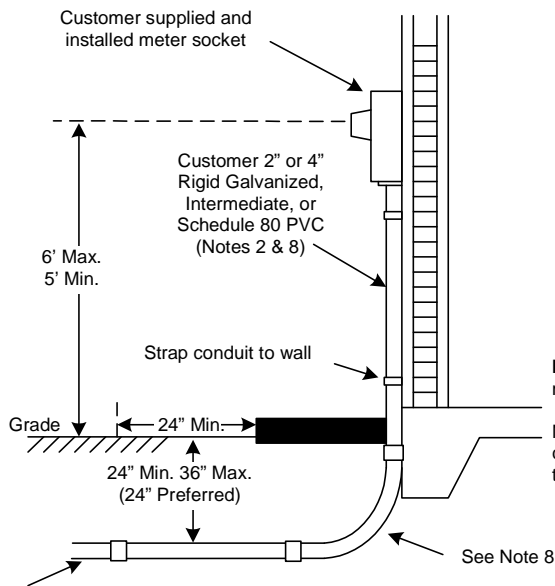
1. Backfill adjacent to cable must be free of boards, debris, and rocks larger than 1" in diameter.
2. Aim service conduit towards designated source of Company's service. End of conduit must be at least 24" away from any permanent structure (patio, porch, etc.) measured at right angle from the structure. Cap or plug the end of pipe.
3. The service lateral must cross the property line within the limits of the easements and should be in a direct line to meter as nearly as practical. It must have at least 5' horizontal clearance to any swimming pool.
4. Conduit bend requirement of National Electrical Code Section 346-10 "the internal diameter of the conduit will not be effectively reduced."
5. With FPL approval, slight variances in customer's downpipe size may be accepted if suitable adapter fitting is also provided by the customer. For example, 2-1/2" downpipe may be accepted if adapter to FPL 2" PVC conduit is provided.
6. Conductor sizes shown in tables are for triplex cables.
7. If load conductors enter from the side, entrance must be opposite side of FPL conductors. When two load conduits are used, they must be kept to one side of the can, allowing space for the line conductors. See [Figure IV-9](#). Center position may not be used for the downpipe.
8. Schedule 80 PVC is acceptable to use, where an obstruction exists at the downpipe the customer must extend the service conduit a minimum of 24" past the obstruction. FPL will provide the 90 degree bend, if the customer provides the 90 degree bend it must be a 24" radius bend. **Field Bends are NOT acceptable!**



FIGURE IV-11b
FPL Buried Service Lateral – Meter Socket & Down Pipe Requirements
(references to notes shown in [Figure IV-11a](#))



EXTENDING CONDUIT 24" BEYOND OBSTRUCTIONS



IMPORTANT – Please distinguish between Overhead and Underground (URD) meter sockets when purchasing. (See FPL Approved List in [Section VII](#)).

Note: If FPL Service Conductors (line side) are parallel #4/0 triplex, then the customer shall provide and install connectors designed for multiple conductors in the meter socket.

Table A – Galvanized or Schedule 80 PVC

Wire Size Cu or Al	Downpipe	90 Degree Bends		45 Degree Bends	
		Bends	Radius	Bends	Radius
1/0 or 4/0	2"	(1) 2" – 90	24"	(2) 2" – 45	18"
2 – 4/0	2 – 2"	(2) 2" – 90	24"	(4) 2" – 45	24"
2 – 4/0	4"	(1) 4" – 90	36"	(2) 4" – 45	24"

FPL Service Cable in Schedule 40 Conduit to padmounted transformer, handhole, or riser (See Notes 1 & 3)



Electric Service Standards

DATE
04-12-16

PREPARED BY

SUBJECT

SECTION: PAGE

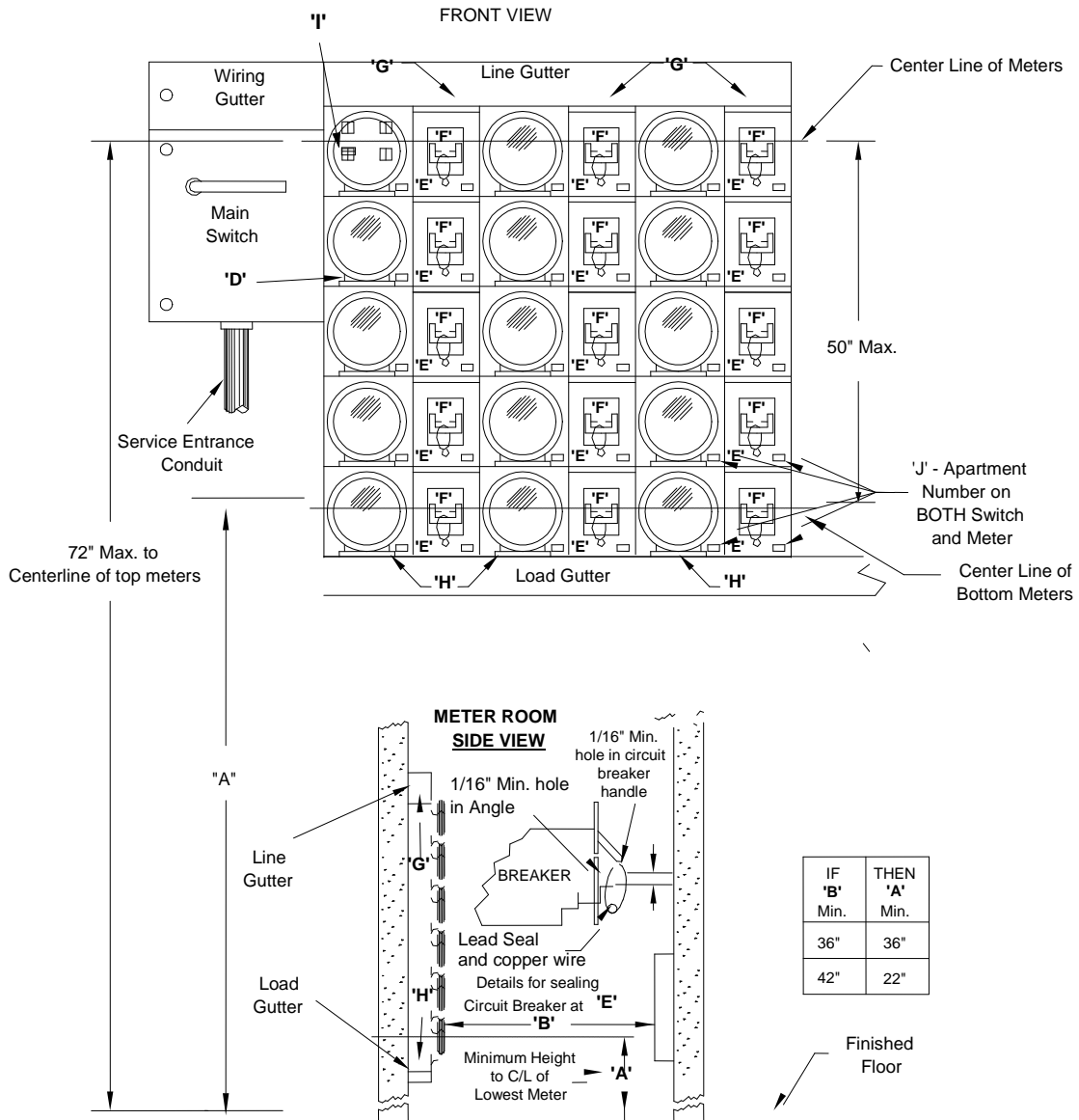
Delivery Assurance –
Design Support

IV. SERVICE and METER CONNECTIONS

IV: 20 of 24

FIGURE IV-12b Residential Multiple Occupancy Buildings - Multiple Meter Center

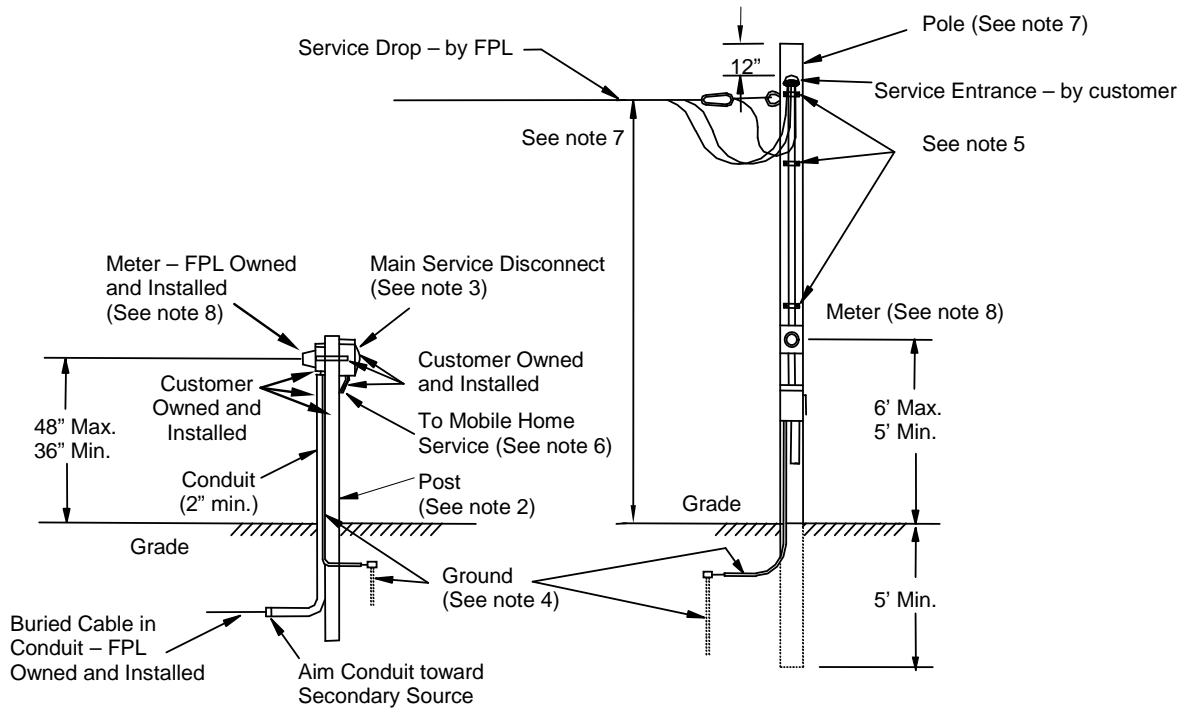
Multiple Meter Center must appear on the Approved List
*Residential Application Shown



- 'B' - Horizontal clearance of meter face to opposite wall or equipment thereon.
- 'D' - Approved captive screw-type sealing ring when socket is ring type.
- 'E' - Provision for sealing each breaker 'F' in off position.
- 'F' - Common trip load breaker for each unit. Breakers are preferred on load side of meter socket.
- 'G' - Fiber or metal barrier at these points to separate line wires from metered circuits.
- 'H' - Fiber or metal barrier at these points to separate metered circuits from line busses.
- 'J' - Permanent and durable identification must be placed on both meter and breaker face plates. Also, mark the inside of the enclosure when possible to do so.
- 'I' - Fifth terminal to be provided when used on 120/208 volt three wire, and is acceptable only in the 9 O'clock position as shown.

* Non-residential and 3 phase applications require lever by-pass, jaw tension/release socket blocks

**FIGURE IV-13a
Remote Meter Location, Typically used for Service to a Mobile Home**



NOTES:

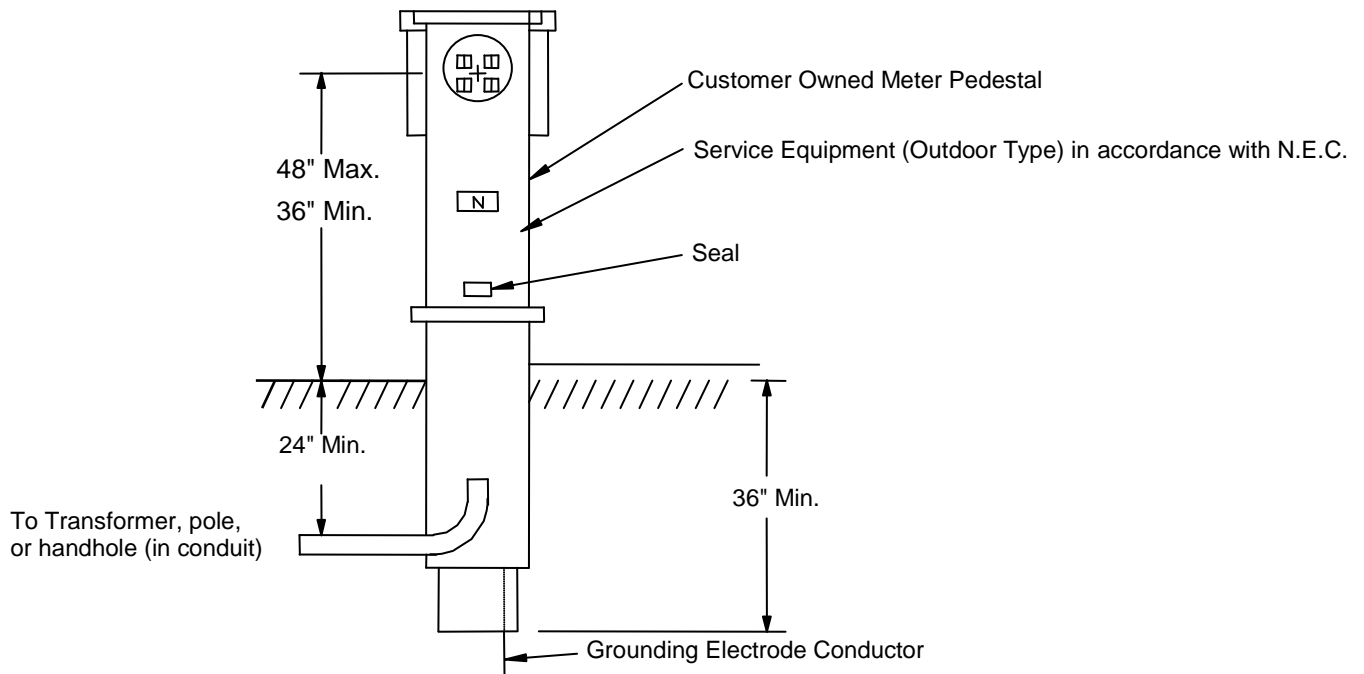
1. Space under meter socket on post to be reserved for conduit.
2. Post to be constructed of reinforced concrete (5"x5"), fiberglass (6"x6" minimum), pressure treated wood (4"x4" minimum), 2" galvanized steel pipe with 2" concrete encasement below ground level, or equivalent.
3. Circuit breaker or main service fused disconnect (outdoor type) National Electrical Code.
4. The customer must ground facilities as required by the National Electrical Code and applicable local codes (refer to section VIII of this FPL Electric Service Standards issue).
5. Customer will install a sufficient number of conduit straps to properly secure conduit to pole.
6. Customer service may be run underground in conduit from bottom of main switch.
7. Customer's class 6 or 7 pressure treated wood pole, or equivalent, set a minimum of 5' deep. Must provide minimum service drop clearances shown in [Figure IV-5](#).
8. Meter - Furnished and installed by FPL. Meter socket furnished and installed by customer.

Class Chart for Douglas Fir and Southern Yellow Pine Poles

Length	Minimum circumference at top		Minimum circumference 6' from butt	
	Class 6	Class 7	Class 6	Class 7
20'	17"	15"	21"	19.5"
25'	17"	15"	23"	21.5"
30'	17"	15"	25"	23.5"
35'	17"	15"	27"	25"

**FIGURE IV-13b
Pedestal Service - Customer Provided Meter Pedestal (typical)**

Meter pedestal must be rigid enough to withstand force applied when meters are installed.



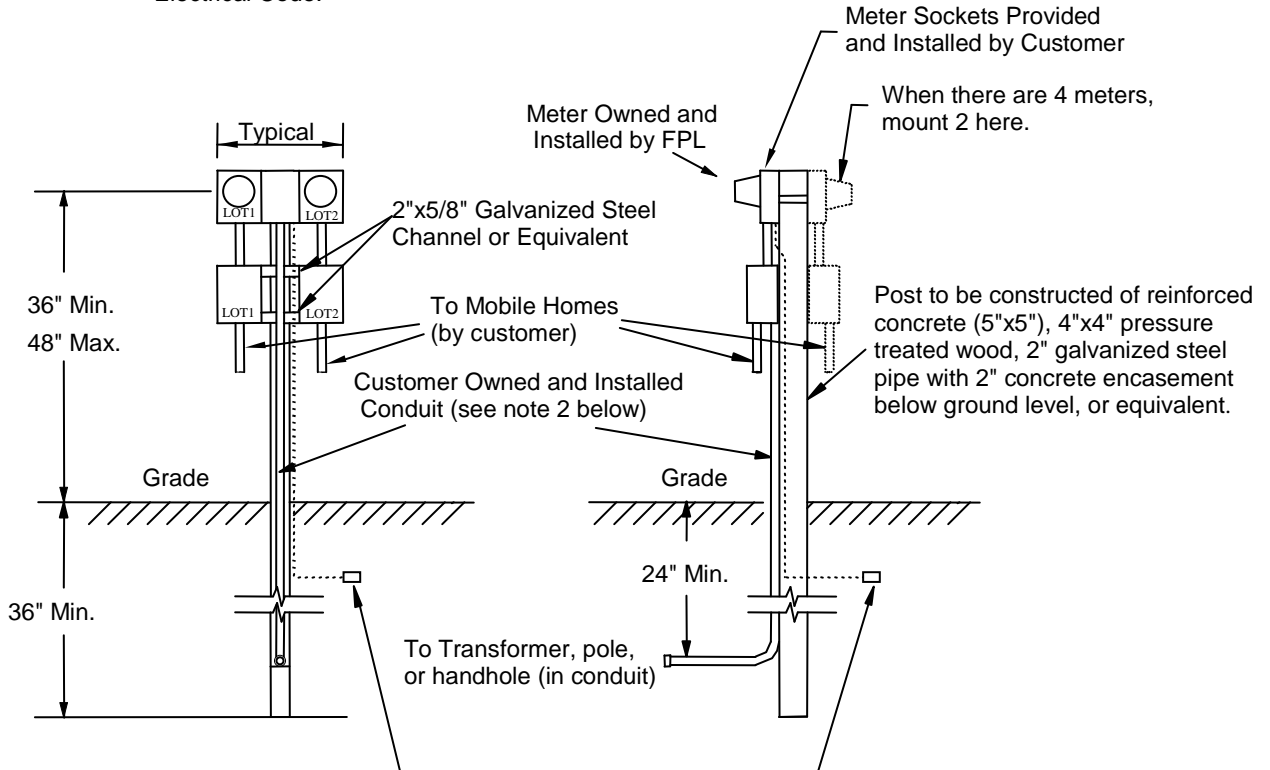
The customer must ground facilities as required by the National Electrical Code and applicable local codes. See [Section VIII](#) of these FPL Electric Service Standards.

Notes:

1. Meter pedestal must be on FPL's approved list, and equipped with standard meter socket.
2. Where FPL is providing the service lateral to the pedestal, refer to [Figure IV-11b](#) for downpipe specifications.
3. FPL Conductors may terminate in customer owned pedestal, but are not to be looped in and out of pedestal.
4. Meter pedestals may be used for residential services or for commercial installations serving non-critical loads. Refer to [IV-A.1](#) for examples.

**FIGURE IV-13c
Mobile Home Service - "Grouped" Service to Mobile Homes**

Main Service Fused Disconnect or Circuit Breaker (Outdoor Type) sized according to the National Electrical Code.



The customer must ground facilities as required by the National Electrical Code and applicable local codes. See [Section VIII](#) of these FPL Electric Service Standards.

NOTES:

1. Customer must permanently and durably mark exterior of meter socket and switch to indicate which unit they serve. Also mark the inside of the enclosure when it is feasible to do so.
2. Where FPL is providing the service lateral to the pedestal, refer to [Figure IV-11b](#) for downpipe specifications.
3. Where FPL is providing the service lateral to the pedestal, a maximum of 4 units is allowed per pedestal.
4. Where FPL is providing the service lateral to the pedestal, FPL conductors will terminate in customer owned pedestal (they'll not be looped in and out of pedestal).



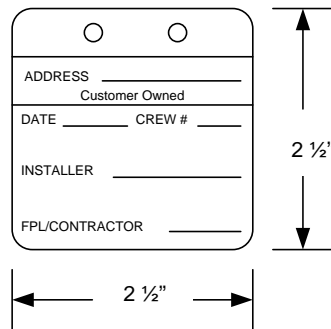
FIGURE IV-14

Identification of Customer Cables

DIRECT BURIED AND CABLE IN CONDUIT SYSTEMS

Use plastic tags as shown in Figure 1 for customer identification at locations that will be subjected to sunlight, such as risers, and also in URD applications for identifying services, such as padmounted transformers and handholes. Plastic tags should have a clear, UV resistant flap to reduce fading and weathering. Use indelible (permanent) marker, and allow 10 seconds drying time to prevent smearing before adhering flap. Fasten tag to cable using plastic tie wraps. Blank tags are available upon request.

Figure 1: Service Tag



Example of proper service tagging:

